

Omni 800

The OMNI 800 offers great flexibility, safety and ease of use. It has been designed specifically for use with a fork lift truck and some similar stacker trucks.

The standard lifting capacity of 800kg.

Fitted with six adjustable 400mm diameter vacuum cups. These are powered by a 24 volt, dual vacuum system for greater safety.

The Lifter is secured to the tyres of the forklift truck and has a full 360 degree rotation for precise positioning and control.

Please contact Packline for further information at sales@packline.co.uk or call 01202 307700.

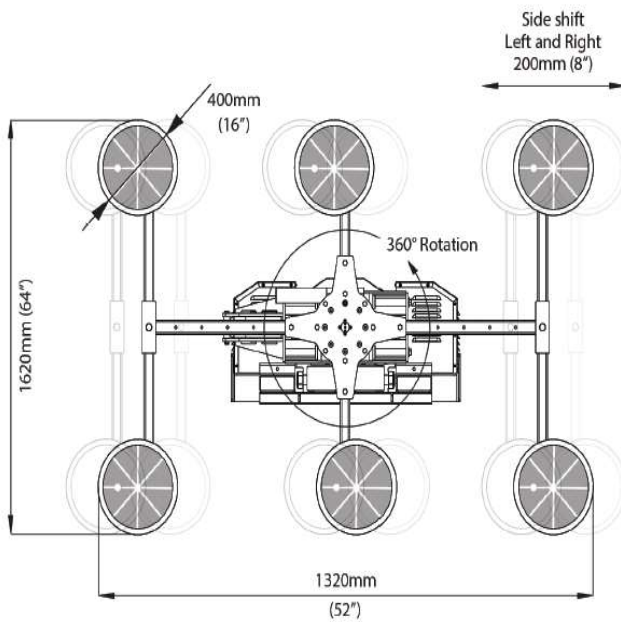
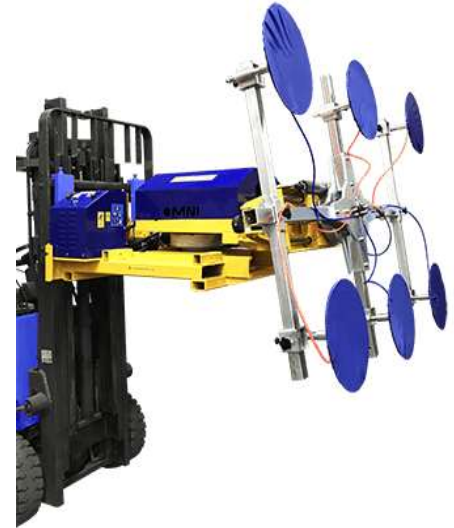

Technical Information

- Capacity 800kg/ 1800lbs
- Two wireless remote controls
- Six adjustable 400mm vacuum cups (spring loaded)
- Dual Vacuum System
- Rotation- 360° 1
- Forward Tilt- 100°
- 180° side pivot. 200mm side shift
- 200mm forward extension
- Express weighs 590kg/ 1300lbs
- 5 axis of precise, electronic movements

